



## 2N Access Control for Luxury Apartments

### Mission

A building, once used as a hospital, in the centre of London was to be turned into 24 apartments. The building was intended for the high-end market, with requirements for luxury equipment and the latest technologies. Integration with a Control4 home automation systems and remote answering of calls from the door were a must. Finally, delivered by our partner CIE and installed by Imaginise, 2N products were implemented.

*"I would certainly recommend the 2N system over the competition - it's proved to have the scalability, the interface and the user-friendly applications that are second nature to people these days. It really is 21st Century technology."*

**Noel O'Dowd, Project Director, Durkan Limited**



### Benefits

- Integration with home automation system
- Scalability of the access control system
- User-friendly application
- Answering calls from anywhere in the world

## Solution

The 2N® IP Verso intercom, in combination with the 2N® Indoor Touch, guarantees an HD video and audio communication. The stylish answering unit, the 2N® Indoor Touch with 7" touchscreen was installed in the apartments. It allows integration into a Home Automation system and due to its Android platform, it can host 3rd party applications. With 2N® Mobile Video installed on smartphones, this would provide for the remote answering of calls from the door if the residents were not at home.

The 2N® IP Verso lets people in at the front doors and main gate. Equipped with an RFID card reader, residents easily swipe their card to get in. Visitors, using a Touch Display module, pick a name from a structured name list or call a flat directly. 2N access units guard an entrance to an underground car park and communal terraces. The 2N IP access control system was managed in bulk by 2N® Access Commander.

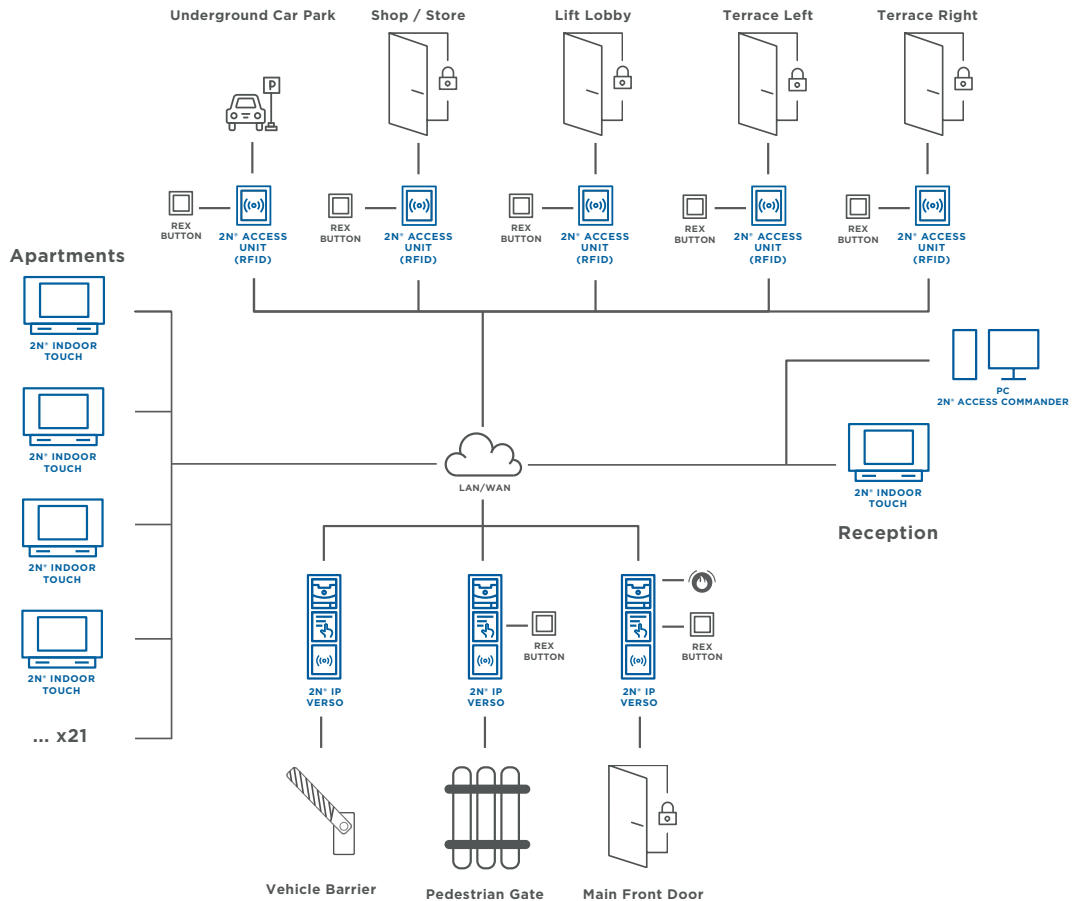

## Result

The residential complex gained a scalable, user-friendly access control system. Due to its IP nature, it can be supported without accessing the site. An advantage was a seamless integration of 2N access control system with Control4 home automation making thus a secure, comfortable and luxurious environment for the residents.

## Installation

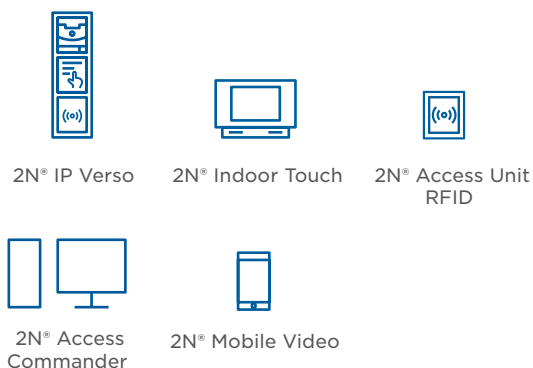

## Our customer

The residential complex is set on the very edge of Putney and overlooking the peaceful common ground just minutes away from Central London.

